

CLEAN STEAM PRODUCTS

COMBO CONDENSATE MEASURING ELBOW

THERMOSTATIC STEAM TRAP

Pressures to 40 PSIG (2.7 barg)
Temperatures to 292°F (144°C)

Sensitivity - The -B bellows has been designed to achieve a 1°C (2-3°F) sub-cool. This is the most sensitive trap in the market place. It maintains backup of condensate below 6" (150mm) for SIP maintenance of vessels sized 40,000 liters and below.

High Capacity - These traps have 30-50% higher capacities than any competitor. This means they can often handle the peak condensate load encountered during vessel heat-up without requiring by-pass through a three-way valve.

Long Life - The single moving part is a multi-plate bellows made of 316L Stainless Steel. The bellows have been tested to exceed 40,000,000 cycles.

Industry Standard Food Grade Gasket - One gasket fits all Nicholson Sanitary Steam Traps. White Viton food grade gasket offers superior performance for higher pressure steam applications.

Water Hammer Protection - Impingement plate protects the bellows and valve from hydraulic shock. This design allows self-centering alignment for superior valve-to-orifice sealing.

Modulating Flow Dynamics - Nicholson Sanitary Steam Traps use conical valves for better flow dynamics, consistent system temperature and pressure and longer life than ball bearing valves.

Self Draining - Completely free draining with the steepest interior surfaces prevents puddling.

Air Venting - Thermostatic element allows for superior air venting and faster system startup.

Cost Efficient - Eliminates clamp on top of CDS

Simplified Validation - Only one unit to validate, complete with all MTRs.

NOTE: Please specify if Material Test Reports (MTR) or Certificates of Conformance (COC) are required.



CONDENSATE MEASURING ELBOW

Applications

- CIP/SIP System Condensate Drainage
- Sterilization of Process Vessels
- Culinary Steam
- Humidifiers
- WFI System Sterilization
- Fermenter Sterilization

Options

- EP - Electropolish
- SLR - SLR Orifice
- Tef-Steel, PTFE, Teflon®, E.P.D.M., USP Class VI & other gasket materials also available
- Horizontal or vertical inlet flow
- Horizontal or vertical well
- Horizontal or vertical outlet flow

Applicable Codes

- ASME BPE

Canadian Registration # OE0591.9

Ordering Code

- CME-A- Direct immersion RTD

Trap Style	Orifice	Outlet Connection	Gasket	Ends and Finish	Well	Bellows
CME	1	6	V	6	NO	B
CME - CoMBo	1 - 204 (5/16")	6 - 1/2"-3/4" 7 - 1" -1 1/2"	V - Viton, E - EPDM P - PTFE, S - Silicone T - Tef-Steel	6 - Tri Clamp, SF1 (MP20 Ra) 7 - Tri Clamp, SF4 (EP 15 Ra)	W2 - 2.5" Well NO - None	B - Sensitive bellows (Std.)

Operation

Thermal actuator is filled at its free length with a liquid having a lower boiling point than water. On start-up, valve is normally open to discharge air, non-condensibles and condensate. When steam enters trap, thermal actuator fill vaporizes to a pressure higher than line pressure. This forces valve into seat orifice to prevent any further flow. As condensate collects, it

takes heat from the actuator, lowering internal pressure. Line pressure will then compress thermal actuator to open valve and discharge condensate. Valve opening automatically adjusts to load conditions from minimum on very light loads to full lift at maximum load. Sensitivity of bellows maintains condensate below thermal probe connection.

COMBO CONDENSATE MEASURING ELBOW THERMOSTATIC STEAM TRAP

SPECIFICATION

Steam trap shall be of balanced pressure design with 316L welded bellows capable of releasing condensate within 1°C (2-3°F) of saturated pressure. All other interior wetted components shall be of 316L stainless. It shall have interior body finish of at least 20 p in. (0.5 µm) Ra and exterior body finish of at least 32 p in. (0.75µm) Ra. Trap shall utilize hygienic body clamp allowing disassembly for inspection or cleaning and be entirely self draining. Trap end connections shall be standard hygienic clamp. Thermostatic actuator shall employ a conical valve lapped to the seat. Traps shall have SLR orifice where drainage at saturated temperatures is required. Traps shall be guaranteed against defects for 3 years. Trap shall maintain condensate below the temperature thermocouple for loads ranging from 1 to 27 lb/hr (0.4 to 12 kg/hr) which are encountered during SIP maintenance of vessels ranging from 20 liters to 40,000 liters respectively.

Maximum operating conditions

PMO: Max. Operating Pressure	40 psig	(2.7 barg)
TMO: Max. Operating Temperature	292°F	(144°C)
PMA: Max. Allowable Pressure	150 psig	(10.3 barg)
TMA: Max. Allowable Temperature	366°F	(186°C)

Materials of construction

Part #	Part Name	Material
1	Condensate Elbow.....	ASME BPE 316L
2	Actuator Nut.....	316L
3	Body Gasket.....	Viton 3227
4	-B Bellows.....	316L
5	Body - Outlet.....	A276 316L
6	Valve.....	316L
7	Body Clamp	304
8	Impingement Plate.....	316L
9	Well.....	316L
10	Well Gasket.....	Viton 3227
11	Well Clamp.....	304

Body Surface Finish

Internal <20µ in. (0.5 µm) Ra SFCI.External <32µ in. (0.75 µm) Ra.

Electropolish SFC4

Gasket Approvals

FDA, CFR Title 21 Part 177, USDA, USP Class VI, 3A Sanitary Standard, NSF

Service Notes

Trap is supplied with the -B Bellows to maintain condensate below the thermal probe. CME-W25 is designed to be self-draining with a horizontal inlet and vertical downward discharge.

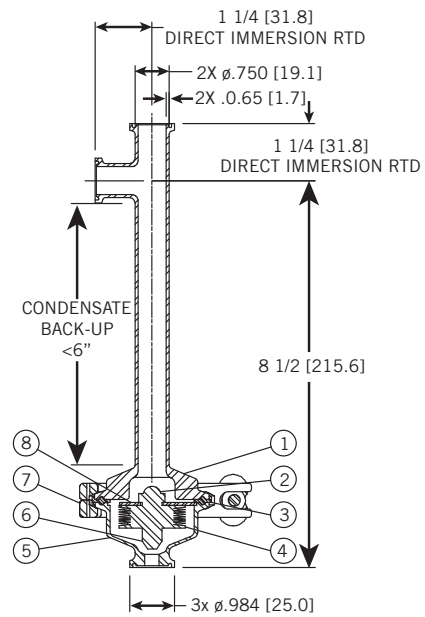

CME-A Direct Immersion RTD
2.8 lbs

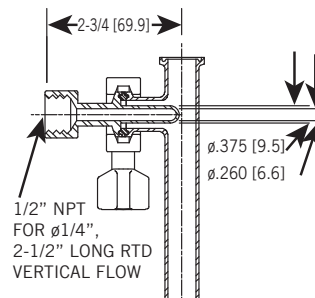

CME-W25 Vertical Flow
2.8 lbs

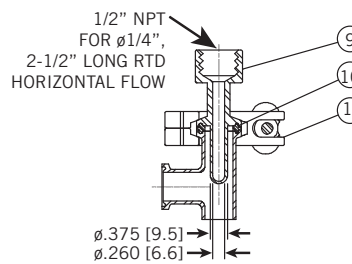

CME-W25 Horizontal Flow

Connections: 3/4" Hygienic Clamp

Condensate Temperature	Orifice Inches	Differential PSIG (bar)							
		5 (0.34)	10 (0.69)	15 (1.03)	20 (1.38)	25 (1.72)	30 (2.07)	35 (2.41)	40 (2.76)
110°F Water (80°C)	5/16	1804 (819)	2551 (1158)	3121 (1417)	3608 (1638)	4015 (1823)	4419 (2006)	4763 (2162)	5030 (2284)
10°F Subcool (5°C)		1520 (690)	1671 (759)	1791 (813)	1869 (849)	1983 (900)	2128 (966)	2212 (1004)	2301 (1045)
3°F Subcool (1.5°C)		682 (310)	775 (352)	835 (379)	861 (391)	915 (415)	975 (443)	995 (452)	1109 (503)

CDS SANITARY

THERMOSTATIC STEAM TRAPS

Pressures to 100 PSIG (6.9 barg)
Temperatures to 338°F (170°C)

Steepest Interior Surfaces - Designed to completely drain without puddling.

Stainless Steel Body - Body Material is 316L Stainless Steel with 20 μ in. Ra internal finish and 32 μ in. Ra external finish. Available with electropolish polishing to 10 μ in. Ra and/or electropolish.

Self centering Valve - Leak tight shut off. Assembly of actuator and valve to impingement plate allows the valve to self align with center of the orifice.

Temperature Sensitive Actuator - One moving part. 316L Stainless Steel, fail open, welded actuator for maximum corrosion, thermal and hydraulic shock resistance.

Directional Discharge - Erosion prevented by directing discharge to center of piping.

Maintenance - Can be easily removed and disassembled for sterilization and/or repair.

Three Year Guarantee - Guaranteed for three years against defects in material or workmanship.

Industry Standard Food Grade Gasket - White Viton food grade gasket offers superior performance for higher pressure steam applications.

Large Orifice Selection - Broad selection of orifice sizes provide greatest sizing and selection flexibility.

Superior Air Handling - Best air handling capability provides for fast startup.

Unique SLR Orifice Option - Provides drainage at saturated temperatures, instant reaction to load changes and guaranteed fail-open operation for extra critical operations.

Bar Stock - Connection fittings are not welded onto inlet and outlet pieces.

MODELS

- **CDS202**—Low capacity
- **CDS203**—Medium capacity
- **CDS204**—High capacity

Operation

Thermal actuator is filled at its free length with a liquid having a lower boiling point than water. On start-up, valve is normally open to discharge air, non-condensibles and condensate. When steam enters trap, thermal actuator fill vaporizes to a pressure higher than line pressure. This forces valve into seat orifice to



Applications

- CIP/SIP System Condensate Drainage
- Sterilization of Process Vessels
- Culinary Steam
- Humidifiers
- WFI System Sterilization
- Fermenter Sterilization

Options

- EP - Electropolish
- SLR - SLR Orifice
- Tef-Steel, PTFE, Teflon®, E.P.D.M., & other gasket materials available
- -B Bellows for low subcool

NOTE: Please specify if Material Test Reports (MTR) or Certificates of Conformance (COC) are required.

Canadian Registration # OE0591.9

prevent any further flow. As condensate collects, it takes heat from the actuator, lowering internal pressure. Line pressure will then compress thermal actuator to open valve and discharge condensate. Valve opening automatically adjusts to load conditions from minimum on very light loads to full lift at maximum load.

CDS SANITARY THERMOSTATIC STEAM TRAPS

SPECIFICATION

Steam trap shall be of balanced pressure design with inconel welded bellows capable of releasing condensate within 10°F of saturated pressure. All other interior wetted components shall be of 316L stainless. It shall have interior body finish of at least 20 μ in. Ra and exterior body finish of at least 32 μ in. Ra. Trap shall utilize sanitary body clamp allowing disassembly for inspection or cleaning and be entirely self draining when installed in vertical configuration. Trap end connections shall be standard tri-clamp. Thermostatic actuator shall employ a conical valve lapped to the seat. A minimum of three orifices shall be available. Traps shall have SLR orifice where drainage at saturated temperatures is required. Traps shall be guaranteed against defects for 3 years.

Maximum operating conditions

PMO: Max. Operating Pressure	100 psig	(6.9 barg)
TMO: Max. Operating Temperature	338°F	(170°C)
PMA: Max. Allowable Pressure	150 psig	(10.3 barg)
TMA: Max. Allowable Temperature	366°F	(186°C)

Body Surface Finish

<20 μ in. Ra internal <32 μ in. Ra external
optional mechanical polishing to 10 μ in. Ra and/or electropolish

Gasket approvals

FDA, USDA, USPH Class 6, 3A Sanitary Standard, NSF

Service Notes

Trap is designed to be self draining for vertical installation (discharge down).
1/2" - 3/4" service trap should be installed with 3/4" inlet gasket.
1" - 1 1/2" service trap should be installed with 1 1/2" inlet gasket.

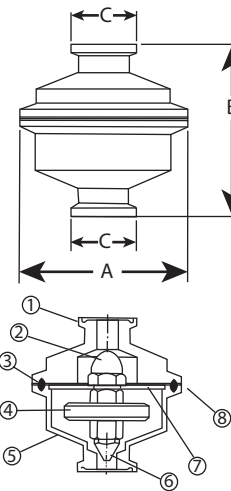

Connections: 1/2" - 1 1/2" Tri-clamp

Service	Dimensions inches (mm)			Weight Lbs. (kg)
	A	B	C	
1/2", 3/4"	2 1/2	2 5/8	6 3/64	1.8
1", 1 1/2"	2 1/2	2 5/8	1 3/64	2.3

Materials of Construction		
Item	Part Name	Material
1	Body - Inlet	316L
2	Actuator Nut	316L
3	Gasket	Viton
4	Actuator	316L
5	Body - Outlet	316L
6	Valve	316L
7	Clamp (not shown)	304
8	Centering Plate	316L

Polishing procedure

All surface finishes are achieved without the use of additional buffing, compounds or grit.

SLR orifice option

Specify when immediate elimination of condensate and improved sensitivity is desired. A 1/32" orifice at the apex of the valve allows for continuous discharge of condensate. Trap will nominally pass 50 lb/hr of condensate at 50 psi within 2°F of saturated temperature.

-B below

3°F subcool for sensitive applications under 45 psi (204 capacity only).

Maximum Capacity—lbs/hr 10°F Below Saturation (Kg/hr 5°C Below Saturation)												
Trap	Orifice Inches	Differential PSIG (barg)										
		5 (0.34)	10 (0.7)	20 (1.4)	30 (2.1)	40 (2.8)	50 (3.4)	60 (4.2)	70 (4.9)	80 (5.6)	90 (6.2)	100 (6.9)
CDS 202	5/32	291 (132)	411 (186)	581 (264)	719 (326)	831 (377)	919 (417)	1000 (454)	1075 (488)	1130 (513)	1174 (533)	1207 (547)
CDS 203	1/4	550 (249)	825 (374)	1210 (549)	1495 (678)	1750 (794)	1975 (896)	2175 (987)	2350 (1066)	2525 (1145)	2650 (1202)	2825 (1281)
CDS 204	5/16	861 (391)	1217 (552)	1722 (781)	2150 (975)	2475 (1123)	2722 (1235)	2940 (1334)	3125 (1417)	3290 (1492)	3450 (1565)	3575 (1622)

For Kg/Hr Multiply by .454

NOTE: Please specify if Material Test Reports (MTR) or Certificates of Conformance (COC) are required.

CDH SANITARY THERMOSTATIC STEAM TRAPS

Pressures To 100 PSIG (6.9 barg)
Temperatures to 338°F (170°C)

Universally Configurable - Horizontal connections from any direction on standard model; AI and AO models feature one multi-directional horizontal and one vertical connection.

Steepest Interior Surfaces - Designed to completely drain without puddling, even in significantly sloped lines.

Stainless Steel Body - Body Material is 316L Stainless Steel with 20 µ in. Ra internal finish and 32 µ in. Ra external finish. Available with electropolish.

Self centering Valve - Leak tight shut off. Assembly of actuator and valve to impingement plate allows the valve to self align with center of the orifice.

Temperature Sensitive Actuator - One moving part. 316L Stainless Steel, fail open, welded actuator for maximum corrosion, thermal and hydraulic shock resistance.

One Size Suits Most Services - Universal ferruled end connection fits both 1/2" and 3/4" piping.

Maintenance - Can be easily removed and disassembled for sterilization and/or repair.

Four Year Guarantee - Guaranteed for four years against defects in material or workmanship.

Inventory Standard Food Grade Gasket - White Viton food grade gasket offers superior performance for higher pressure steam applications.

Superior Air Handling - Best air handling capability provides for fast startup.

Unique SLR Orifice Option - Provides drainage at saturated temperatures, instant reaction to load changes and guaranteed fail-open operation for extra critical operations.

Bar Stock - Connection fittings are not welded onto inlet and outlet pieces

MODELS

- **CDH-AI-AO**—Horizontal inlet and outlet
- **CDH-AI**—Horizontal inlet, vertical outlet
- **CDH-AO**—Vertical inlet, horizontal outlet

Operation

Thermal actuator is filled at its free length with a liquid having a lower boiling point than water. On start-up, valve is normally open to discharge air, non-condensibles and condensate. When steam enters trap, thermal actuator fill vaporizes to a pressure higher than line pressure. This forces valve into seat orifice to

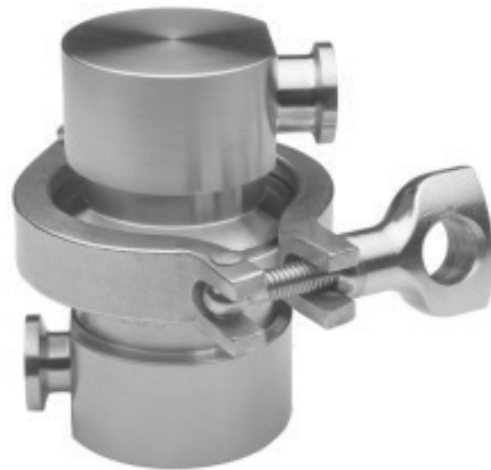

Applications

- CIP/SIP System Condensate Drainage
- Sterilization of Process Vessels
- Culinary Steam
- Humidifiers
- WFI System Sterilization
- Fermenter Sterilization

Options

- EP - Electropolish
- SLR - SLR Orifice
- Tef-Steel, PTFE, Teflon®, E.P.D.M., & other gasket materials available
- -B Bellows for low subcool

NOTE: Please specify if Material Test Reports (MTR) or Certificates of Conformance (COC) are required.

Canadian Registration # OE0591.9C

prevent any further flow. As condensate collects, it takes heat from the actuator, lowering internal pressure. Line pressure will then compress thermal actuator to open valve and discharge condensate. Valve opening automatically adjusts to load conditions from minimum on very light loads to full lift at maximum load.

CDH SANITARY THERMOSTATIC STEAM TRAPS

SPECIFICATION

Steam trap shall be of balanced pressure design with inconel welded bellows capable of releasing condensate within 10°F of saturated pressure. All other interior wetted components shall be of 316L stainless. It shall have interior body finish of at least 20 μ in. Ra and exterior body finish of at least 32 μ in. Ra. Trap shall utilize sanitary body clamp allowing disassembly for inspection or cleaning and be entirely self draining in horizontal or angle piping configuration. Trap end connections shall be standard tri-clamp. Thermostatic actuator shall employ a conical valve lapped to the seat. Traps shall have SLR orifice where drainage at saturated temperatures is required. Traps shall be guaranteed against defects for four years.

Maximum operating conditions

PMO: Max. Operating Pressure	100 psig	(6.9 barg)
TMO: Max. Operating Temperature	338°F	(170°C)
PMA: Max. Allowable Pressure	150 psig	(10.3 barg)
TMA: Max. Allowable Temperature	366°F	(186°C)

Body surface finish

<20 μ in. Ra internal <32 μ in. Ra external
optional electropolish

Gasket approvals

FDA, USDA, USPH Class 6, 3A Sanitary Standard, NSF

SLR orifice option

Specify when immediate elimination of condensate and improved sensitivity is desired. A 1/32" orifice at the apex of the valve allows for continuous discharge of condensate. Trap will nominally pass 50 lb/hr of condensate at 50 psi within 2°F of saturated temperature.

Connection

Sanitary Ferrule accommodates 1/2" and 3/4" service

-B below

3°F subcool for sensitive applications under 45 psi (204 capacity only).

Polishing procedure

All surface finishes are achieved without the use of additional buffing, compounds or grit.

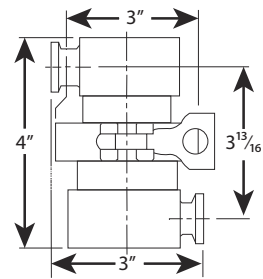

CDH-AI-AO - 3.9 LB.

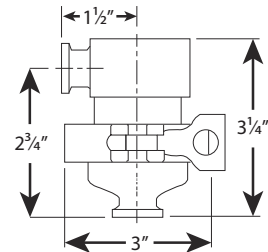

CDH-AI - 2.6 LB.

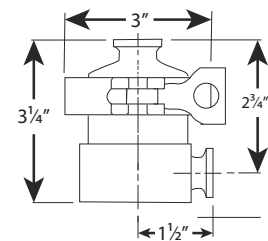

CDH-AO - 3.1 LB.

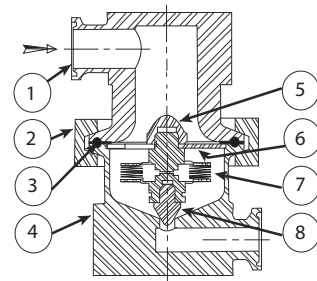

Connections: 1/2" Tri-clamp

PATENT PENDING

Materials of Construction

Item	Part Name	Material
1	Body - Inlet	316L
2	Clamp	304
3	Gasket	Viton
4	Body - Outlet	316L
5	Actuator Nut	316L
6	Centering Plate	316L
7	Actuator	I316L SS
8	Valve	316 L

Maximum Capacity—lbs/hr 10°F Below Saturation (Kg/hr 5°C Below Saturation)

Trap	Orifice Inches	Differential PSIG (barg)										
		5 (0.34)	10 (0.7)	20 (1.4)	30 (2.1)	40 (2.8)	50 (3.4)	60 (4.2)	70 (4.9)	80 (5.6)	90 (6.2)	100 (6.9)
CDH	1/4	550 (249)	825 (374)	1210 (549)	1495 (678)	1750 (794)	1975 (896)	2175 (987)	2350 (1066)	2525 (1145)	2650 (1202)	2825 (1281)

For Kg/Hr Multiply by .454

DS100/DS110

THERMOSTATIC STEAM TRAPS

Pressures To 150 PSIG (10.3 barg)
Temperatures to 366°F (186°C)

Stainless Steel Body - Body materials of all models are Type 316L Stainless Steel.

Self Centering Valve - Leak tight shut off. Assembly of actuator and valve to impingement plate allows valve to self-align with center of valve seat orifice. Provides long lasting valve and seat.

Temperature Sensitive Actuator - 316L Stainless welded actuator for maximum corrosion, thermal and hydraulic shock resistance. One moving part.

Thermal and Hydraulic Shock Resistant - Impingement plate plus welded construction prevents damage to actuator.

Long Life Valve and Seat - Stainless steel valve and seat matched together for water tight seal.

Maintenance - All models are sealed and maintenance free.

Directional Discharge - Erosion prevented by directing discharge into the center of pipe or tubing.

Best Air Handling Capacity - Fast start up and operation.

Fast Response - Quickly adjusts to condensate load or temperature changes.

One Size Suits Most Services - Universal ferruled end connection fits both 1/2" and 3/4" piping.

Two Year Guarantee - Trap guaranteed for two years against defects in material or workmanship.

MODELS

- **DS100**—Ferrule clamp end 1 $\frac{7}{8}$ " OAL
- **DS100TE**—Tube end
- **DS110**—Ferrule clamp end 2 $\frac{5}{8}$ " OAL



Applications

- CIP/SIP System Condensate Drainage
- Sterilization of Process Vessels
- Culinary Steam
- Humidifiers
- WFI System Sterilization
- Main Drips

Options

- Check Valve for DS110

NOTE: Please specify if Material Test Reports (MTR) or Certificates of Conformance (COC) are required.

Canadian Registration # 0E0591.9C

Operation

Thermal actuator is filled at its free length with a liquid having a lower boiling point than water. On start-up, valve is normally open to discharge air, non-condensibles and condensate. When steam enters trap, thermal actuator fill vaporizes to a pressure higher than line pressure. This forces valve into seat orifice to

prevent any further flow. As condensate collects, it takes heat from thermal actuator, lowering internal pressure. Line pressure will then compress thermal actuator to open valve and discharge condensate. Valve opening automatically adjusts to load conditions from minimum on very light loads to full lift at maximum load.

DS100/DS110

THERMOSTATIC STEAM TRAPS

SPECIFICATION

Steam trap shall be thermostatically actuated and maintenance free. Actuator shall be of single piece, fail open design consisting of 1.2" diameter, welded 316L stainless plates. Trap shall be constructed entirely of 316L stainless steel components with wetted body surfaces finished to 20 μ inch Ra or better. Trap shall be self draining when installed vertically in piping systems. Trap shall have tube or universal ferruled connections. Ferruled connections shall be Tri-clamp compatible and designed to fit both 1/2" and 3/4" service. Trap shall be guaranteed against defects for 2 years.

Maximum operating conditions

PMO: Max. Operating Pressure	150 psig	(10.3 barg)
TMO: Max. Operating Temperature	366°F	(170°C)
PMA: Max. Allowable Pressure	300 psig*	(20.7 barg)
TMA: Max. Allowable Temperature	500°F	(260°C)

Body surface finish

<20 μ in. Ra internal
Machine Polished external

Service notes

Trap is designed to be self draining for vertical installation (discharge down).

1/2" - 3/4" ferrule service trap should be installed with 3/4" inlet gasket.

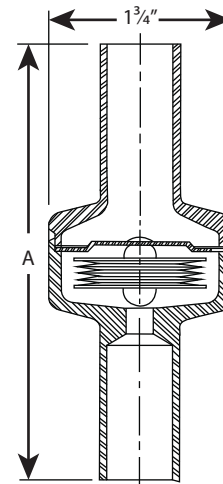
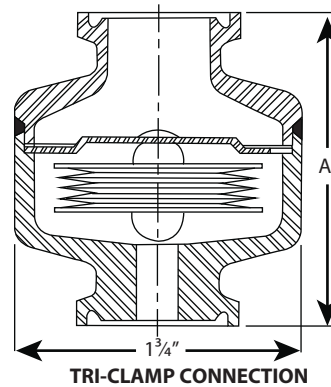

Connections: 1/2" - 1" Tube 1/2 3/4" Tri-clamp

Dimensions			
Trap	End Connections	Size	inches (mm) A
DS100	Tube	1/2", 3/4", & 1"	4 7/8 (104.8)
DS100	Ferrule	1/2", & 3/4"	1 7/8 (47.6)
DS110	Ferrule	1/2", & 3/4"	2 5/8 (66.7)

Materials of Construction	
Part Name	Material
Body - Inlet	316L
Actuator	316L
Body - Outlet	316L
Valve	316L

Maximum Capacity—lbs/hr 10°F Below Saturation (Kg/hr 5°C Below Saturation)														
Trap	Orifice Inches	Differential PSIG (barg)												
		5 (0.34)	10 (0.7)	20 (1.4)	30 (2.1)	40 (2.8)	50 (3.4)	60 (4.2)	70 (4.9)	80 (5.6)	90 (6.2)	100 (6.9)	125 (8.62)	150 (10.3)
DS 100	1/4	550 (249)	825 (374)	1210 (549)	1495 (678)	1750 (794)	1975 (896)	2175 (987)	2350 (1066)	2525 (1145)	2650 (1202)	2825 (1281)	3140 (1424)	3425 (1554)

DS200 SERIES

THERMOSTATIC STEAM TRAPS

Pressures To 100 PSIG (6.9 barg)
Temperatures to 338°F (170°C)

Stainless Steel Body - Body materials are Type 316L Stainless Steel.

Self Centering Valve - Leak tight shut off. Assembly of actuator and valve to impingement plate allows valve to self-align with center of valve seat orifice. Provides long lasting valve and seat.

Temperature Sensitive Actuator - One moving part. Inconel welded actuator for maximum corrosion, thermal and hydraulic shock resistance.

Thermal and Hydraulic Shock Resistant - Impingement plate plus welded construction prevents damage to actuator.

Valve and Seat - Long life, stainless steel valve and seat lapped and matched together for water tight seal.

Maintenance - All models are sealed and maintenance free.

Three Year Guarantee - Trap guaranteed for three years against defects in material or workmanship.

Additional Features - Best air handling capability for fast start up and operation. Fastest response to condensate load or temperature changes. Broad application range. Selection of orifice and pipe sizes meet majority of condensate removal demands in deionized steam systems.

Unique SLR Orifice Option - Provides drainage at saturated temperatures, instant reaction to load changes and guaranteed fail-open operation for extra critical operations.

Applications

- Platen Presses
- Plating Tanks
- Sterilizers
- Tire Presses
- Cooking Equipment
- Laundry Equipment
- Other Process Equipment

Canadian Registration # OE0591.9C

Operation

Thermal actuator is filled at it's free length with a liquid having a lower boiling point than water. As assembled, valve is normally open. On startup, air passes through vent. As air is eliminated, hot steam reaches vent and the thermal actuator fill vaporizes to a pressure higher than line pressure. This forces



MODELS

- **DS202**—Low capacity
- **DS203**—Medium capacity
- **DS204**—High capacity

valve into seat orifice to prevent any further flow. Should more air collect, it takes heat from the actuator, lowering internal pressure. Line pressure will then compress thermal actuator to open valve and discharge air. Valve lift automatically adjusts to variations.

DS200 SERIES

THERMOSTATIC STEAM TRAPS

SPECIFICATION

Steam trap shall be of balanced pressure design with stainless steel welded bellows capable of releasing condensate within 10°F of saturated pressure. Where drainage at saturated temperatures is required, trap shall have SLR orifice. All other components shall be of 316 or 316L stainless steel. Trap shall be self draining and normally open.

Maximum operating conditions

PMO: Max. Operating Pressure	100 psig	(6.9 barg)
TMO: Max. Operating Temperature	338°F	(170°C)
PMA: Max. Allowable Pressure	150 psig*	(10.3 barg)
TMA: Max. Allowable Temperature	366°F	(186°C)

Materials of construction

Body ASTM 743 CF-8M Stainless Steel
 1" - 316SS, ASME SA479
 Welded Actuator 316L Fittings & Plates
 Valve & Seat 316L Stainless Steel

SLR Orifice Option

Specify when immediate elimination of condensate and improved sensitivity is desired. A 1/32" orifice at the apex of the valve allows for continuous discharge of condensate. Trap will nominally pass 50 lbs/hr of condensate at 50 psi within 2°F of saturated temperature.

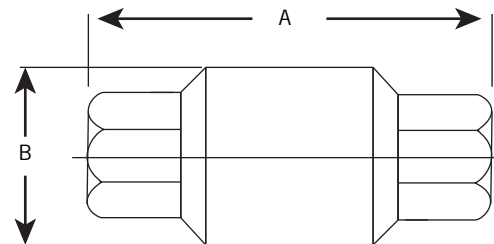

3/8" - 3/4" BODY

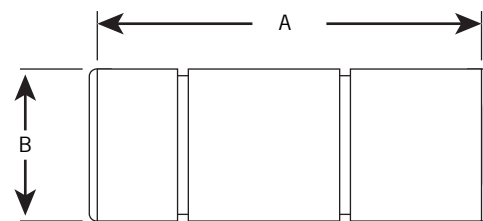

1" BODY

Connections: 3/8" - 1" NPT or socketweld

Dimensions			
NPT or Socket weld	Inches (mm)		Weight Lbs. (kg)
	A	B	
3/8", 1/2"	3 3/4 (95)	1 3/4 (44)	1.1 (0.5)
3/4"	3 15/16 (100)	1 3/4 (44)	1.2 (0.54)
1"	4 3/8 (111)	1 3/4 (44)	1.6 (0.73)

Maximum Capacity—lbs/hr 10°F Below Saturation (Kg/hr 5°C Below Saturation)															
Trap	Orifice Inches	Differential PSIG (barg)													
		5 (0.34)	10 (0.7)	20 (1.4)	50 (3.5)	100 (6.9)	125 (8.6)	150 (10.3)	200 (13.8)	250 (17.2)	300 (20.7)	350 (24.1)	400 (27.6)	450 (31.0)	500 (34.5)
DS202	1/8 (3)	216 (98)	265 (120)	375 (170)	592 (269)	778 (354)	838 (381)	890 (405)	980 (445)	1055 (480)	1121 (510)	1180 (536)	1235 (561)	1284 (584)	1323 (601)
DS203	1/4 (6)	550 (249)	825 (374)	1210 (549)	1975 (896)	2825 (1281)	3140 (1424)	3425 (1554)	3650 (1656)	3960 (1796)	4100 (1860)	4230 (1919)	4420 (2005)	4600 (2086)	4760 (2161)
DS204	5/16 (8)	860 (390)	1220 (554)	1725 (783)	2725 (1237)	3575 (1623)	3850 (1748)	4090 (1857)	4505 (2045)	4850 (2202)	5155 (2340)	5425 (2463)	5675 (2576)	5900 (2679)	6110 (2774)

